

San Joaquin County Department of Public Works
LOVELACE MATERIALS RECOVERY FACILITY AND TRANSFER STATION

Owned and Operated by San Joaquin County Since July 1, 1977

PRICE SHEET - Effective January 1, 2025

SITE INFORMATION:

LOCATION: 2323 East Lovelace Road, east of Airport Way, Manteca, California 95336

PHONE: (209) 982-5770 / (209) 858-4061 (FAX)

For questions regarding these rates, please call 209-468-3066.

HOURS: Open 7 days a week - 7:00 am to 4:00 pm for all customers.

(Operating hours will be strictly followed. No exceptions)

Closed: New Year's Day, Easter Sunday, Thanksgiving Day, and Christmas Day

SIZE: 15 Acres

Daily Peak Permitted Waste Quantity 1,300 Tons

Annual Waste Received (2023) 260,777 Tons

Average Daily Waste Received (2023) 721 Tons

PREFERRED FORMS OF PAYMENT:

Credit or Debit cards, or business checks with preprinted business information only. **No cash accepted.**

ACCEPTABLE WASTE:

Commercial and household waste; agricultural waste; tires; white goods (e.g., refrigerators, freezers, and A/C Units); small loads of concrete, soil, rocks, gravel, or asphalt; large bulky items/hard-to-handle materials. Oil filters (Limit 12).

UNACCEPTABLE WASTE:

Septic tank waste; some types of construction/demolition waste**; toxic materials; dead animals; drums larger than 5 gallons; Infectious waste; liquid waste; cannery waste; hazardous waste; ammonia refrigerant unit; logs and tree stumps; used cooking oil from commercial haulers; burned wastes; large loads of concrete, soil, rocks, gravel, or asphalt; pressure treated, and creosote coated wood.

**Items of sufficient weight, mass, hardness or difficulty in processing that may damage facility equipment

RATES

Customers with UNCOVERED/UNSECURED LOADS must pay a double disposal fee or purchase a tarp.

VEHICLE RATES/MINIMUM FEES: (Based on vehicle type and not on the amount of refuse contained in vehicle)

Automobiles.....	\$21.00
Pickups with bed less than 8' in length (if load is at or below cab level).....	\$24.25
Pickups with bed less than 8' in length (if load is above cab level).....	\$31.50
Pickups with bed 8' in length (if load is at or below cab level).....	\$37.25
Pickups with bed 8' in length (if load is above cab level).....	\$55.75
Trailers 8' or less in length (if load is at or below cab level)	\$37.25
Trailers 8' or less in length (if load is above cab level).....	\$55.75
Vans 8' or less in length (from the last seat to the rear)	\$33.75

ALL OTHER VEHICLES:

Vehicles Charged by Weight (Per Ton).....\$76.15 per Ton (Minimum charge at \$37.25)

Vehicles Charged by Cubic Yard (when scales are down)..... \$24.25 per Cubic Yard

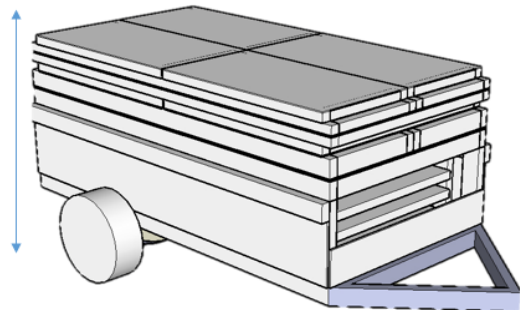
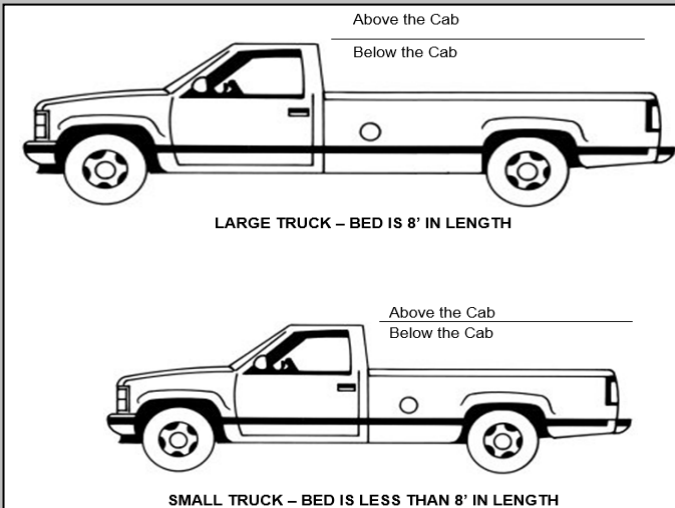

6' - 8' IN HEIGHT=Below Cab
 8' - 10' IN HEIGHT=Above Cab
 LESS THAN OR EQUAL TO 8' LENGTH*

≥10' IN HEIGHT = CHARGED BY WEIGHT
 GREATER THAN 8' LENGTH*

*All Trailers Over 8' In Any Direction Charged By Weight

LOVELACE MATERIALS RECOVERY FACILITY AND TRANSFER STATION RATES (Continued)

SPECIAL CHARGES (Proof of San Joaquin County Residency is required for special waste at no charge)

Tires

Motorcycle Tires.....	Mounted \$7.25 ea./Unmounted \$6.25 ea.
Passenger Tires or Smaller.....	Mounted \$7.25 ea./Unmounted \$6.25 ea.
Truck Tires.....	Mounted \$11.75 ea./Unmounted \$9.75 ea.
Residents: Motorcycle, passenger, small truck tires	Four (4) Per Trip @ No Charge
Truck Tires: Larger than 12.00 x 24.....	\$17.50 ea.
Farm Tractor Tires: No larger than 17.5 x 24.....	\$19.75 ea.
Loader Tires: No larger than 23.5 x 25.....	\$164.00 ea.
Earth Moving Tires: Larger than 23.5 x 25.....	\$492.25 ea.

Appliances (e.g., A/C Units, Freezers, Refrigerators)

Residents:	Two (2) Per Trip @ No Charge
Residents: Additional or Unemptied units per load, any combination.....	\$19.25 ea.
Businesses/Non-Residents: Units per load, any combination.....	\$19.25 ea.

E-Waste (e.g., TVs/CRTs/Computer Monitors)

Residents:	Four (4) Per Trip @ No Charge
Residents: Additional units per load, any combination.....	\$23.00 ea.
Businesses/Non-Residents: Units per load, any combination.....	\$23.00 ea.

Mattress or Box Spring

Residents:.....	Ten (10) Per Trip @ No Charge
Residents: Additional units per load.....	\$19.25 ea.
Businesses/Non-Residents: Normal weighed waste fees apply to entire load, up to limit of 30 units	\$76.15 per Ton. (Minimum charge at \$37.25)

E-Waste/U-Waste (e.g., Fluorescents/Batteries/Electronics)

Residents:.....	Combined Nine (9) Per Trip @ No Charge. No additional units accepted.
-----------------	--

SPECIAL HANDLING FEES:

Large Bulky Items/Hard-to-Handle	\$119.83 per ton. (Minimum charge at \$37.25)
Items including but not limited to: Mobile homes, RV trailers, camper trailers 25 feet or less in length (remove thermostats and appliances, dismantle the camper/trailer/vehicle into small sections, and bring a Junk Slip from DMV), boats, large concrete, wire, tree stumps, large/long pipes, drip hoses and large wooden/metal beams.	

(For more information, please visit the County's website at www.SJCreycle.org)