



**SAN JOAQUIN COUNTY  
COMMUNITY DEVELOPMENT DEPARTMENT**

1810 E. HAZELTON AVE., STOCKTON, CA 95206-6232  
PHONE: 209/468-3121 FAX: 209/468-3183

PITCHED ROOF CONSTRUCTION OVER EXISTING FLAT TOP CONSTRUCTION

The following items are required in conjunction with the issuance of a building permit.

1. Site plan showing lot dimensions and building setback dimensions.
2. A roof plan of the existing dwelling showing building contour in broken lines and interior bearing walls to be used for purlin braces.
3. Detail bearing connection to existing exterior bearing wall.
4. Eaves shall be not less than 30 inches from the side and rear property lines.
5. Existing roofing will be stripped at all support locations.
6. Extend all plumbing and appliance vents per code.
7. Non-conforming appliance vents shall be completely replaced.
8. Extend masonry chimney per code; reinforce with 4-#4 vertical bars and lap existing bars - 20" by breaking back chimney. 1/4" steel hoops shall be placed at intersection and each 18" vertically.
9. Purlin braces shall occur over interior partitions.
10. Extend or provide firewall separation to roof sheathing in garage.
11. Indicate minimum 20" x 30" proposed attic access location. (Not permitted in garage firewall unless fire rated.)
12. Provide attic ventilation equal to the attic area divided by 150 or one half that amount if the vents are located both in the eaves and above the center of the roof.
13. A battery type smoke detector(s) is required in all bedrooms, hallway's and where ceiling height of a room open to the hallway serving the bedrooms exceeds the hallway by 24".
14. Detail structure to support the air conditioning unit on the new roof or if the unit is proposed to remain on the existing roof show required clearances from the new structure, flashings, and positive drainage.
15. Energy Requirements:
  - a) Install radiant barrier roof sheathing.
  - b) Install R-30 minimum roof insulation.

**NOTE:** Call for a frame inspection before installing any roofs sheathing. The fireplace will be inspected during this inspection.



**SAN JOAQUIN COUNTY  
COMMUNITY DEVELOPMENT DEPARTMENT**

1810 E. HAZELTON AVE., STOCKTON, CA 95205-6232  
PHONE: 209/468-3121 FAX: 209/468-3183

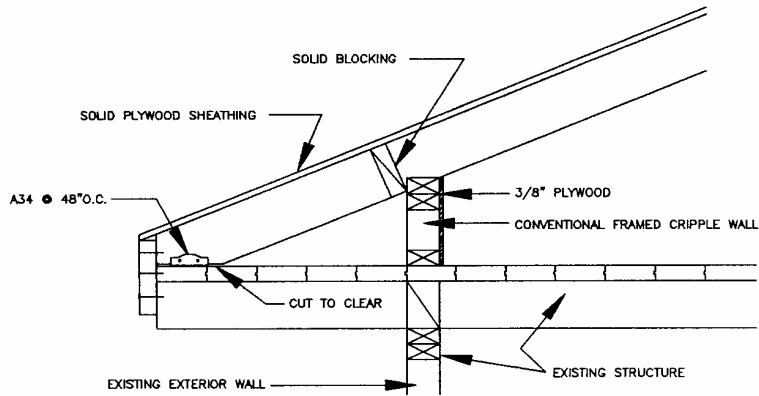

FLAT ROOF TO 5:12 PITCH OR GREATER

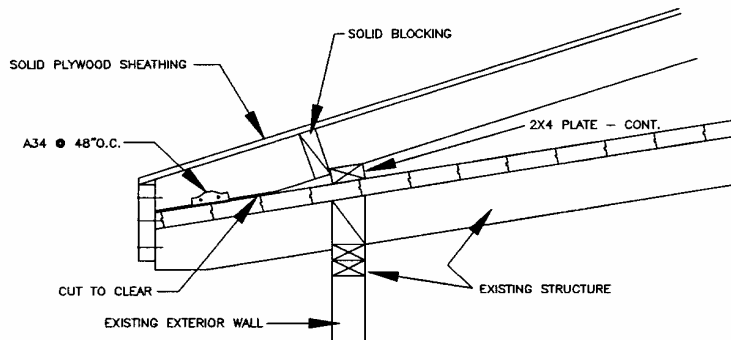

2:12 PITCH TO 4:12 PITCH

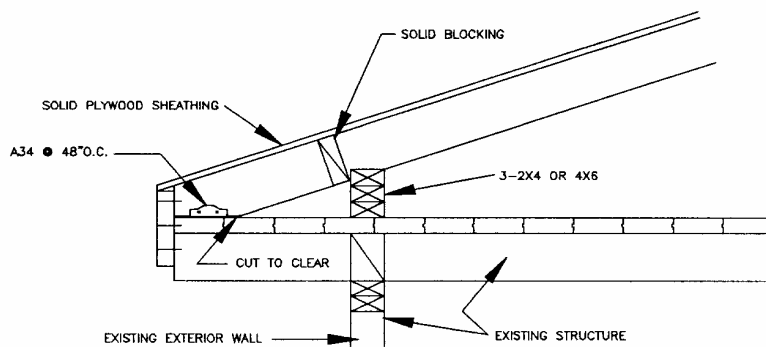

FLAT ROOF TO 4:12 PITCH